

KLS01 700MM DIA LAZY SUSAN INSTALLATION GUIDE

TOOLS REQUIRED: PHILLIPS SCREW DRIVER, DRILL & 2MM DRILL BIT

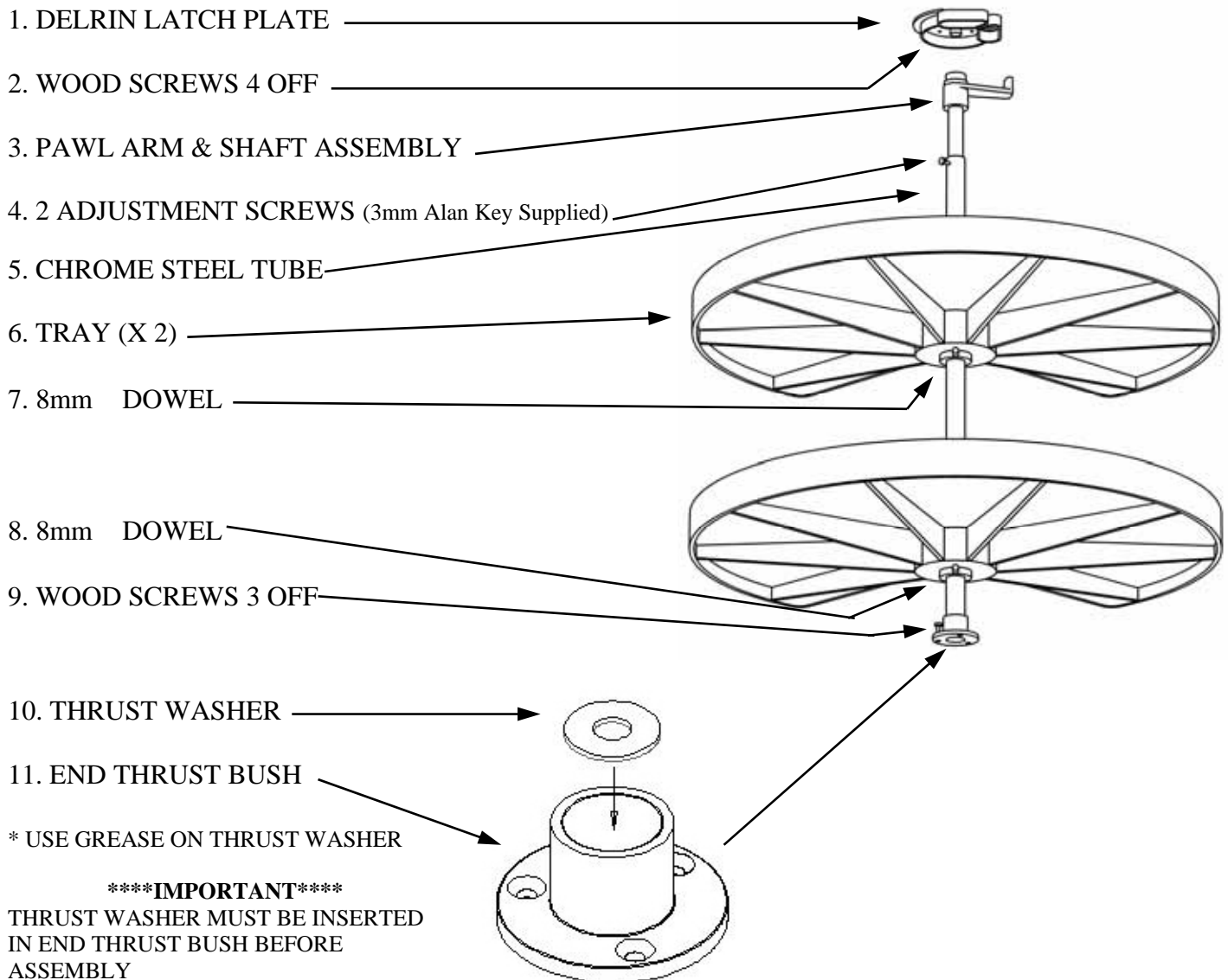

- Using bottom template provided on the reverse side mark holes. Check you are satisfied with shelf position then drill as shown and fix end thrust bush with screws provided.
- Using template drill top and fix delrin latch plate with screws provided.
- Slide two shelves on shaft assembly.
- Fit shaft into end thrust bush and slide up pawl arm shaft assembly. Locate in latch plate and tighten adjusting screw (lightly).
- Locate trays to tube with 8mm \varnothing dowels provided.
- Position cut out section of tray to correct setting and tighten adjusting screw.

TOP TEMPLATE

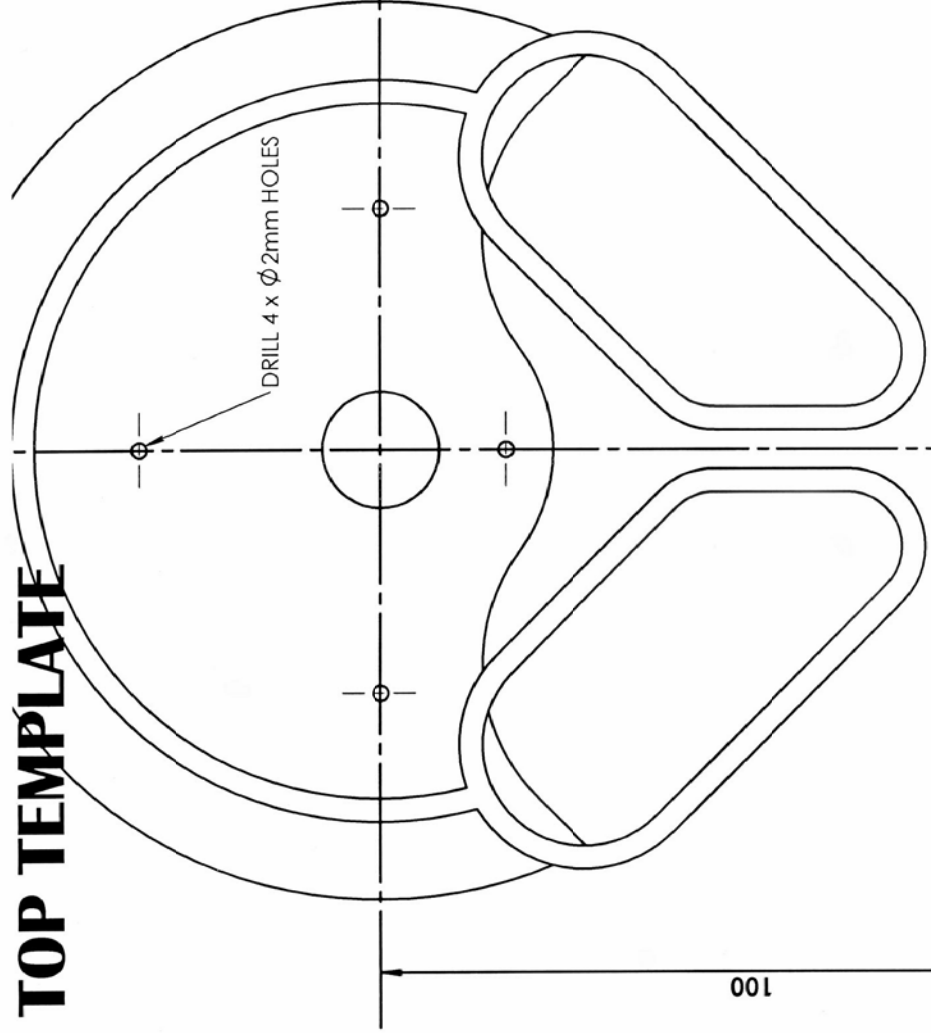

DELRIN LATCH PLATE

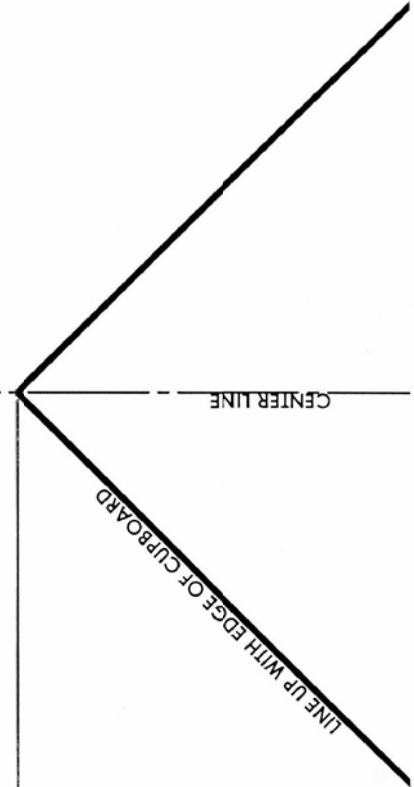

BOTTOM TEMPLATE

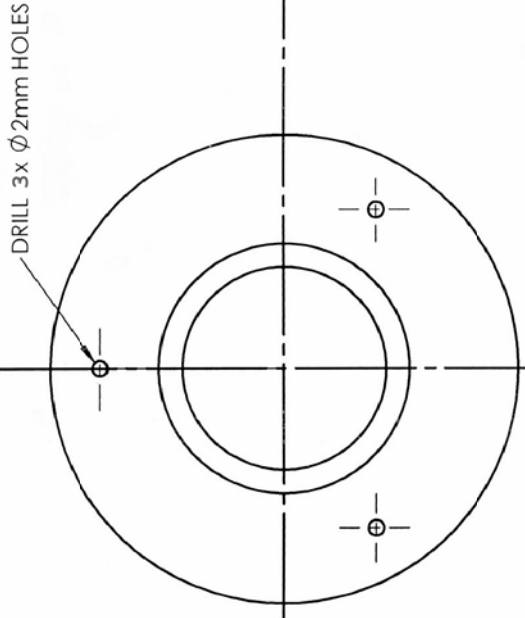

BOTTOM END THRUST BUSH

