



1. Ultimate series fitted to double carport, timber paneling is also fixed to hatch door to provide a consistent finish to the ceiling. This provided access for the owner into area over the garage as well as the carport.
2. The use of a short passageway with this 1940's dwelling provided the owners access into tallest area under roof.

ACCESS ALL AREAS

An economical and easy solution to access your roof storage area, Kimberley's Premium Wood and Heavy Duty Aluminium access stairs are the highest quality on the market.

Improving and superseding old methods of access with a safer and more affordable design, Kimberley have extended their range from home and dwelling attic access to warehouse, workshop and medical facility access stairs, and commercial access stairs for air-conditioning, maintenance, HVAC, telecommunications and storage lofts.

The standard series for residential use includes eight Wood and Aluminium models, ranging from 2130 to 3048mm in height. They are simple to install, with an exclusive EZ-Hang strap system that acts as a temporary support during the process. Quality construction ensures strength and longevity. The power arm hinge features one piece construction with no welded joints, while the wood or aluminium steps are secured with reinforcing rods and riveted bracing.

The ladder units are factory assembled, and only need to be fitted to your cut ceiling or mezzanine opening. Easy to read instructions and a complete installation kit help quickly set the ladder in place.

In 2006, Kimberley created the Ultimate series, designed for commercial applications with its heavy duty load strain, wide steps and easy-close gas strut operation that does away with bulky springs and door slamming. Its high strength riveted construction is load rated for up to 150kg, with aluminium extrusions for added strength. Ultimate access ladders differ from other products by maintaining the same spacing between steps, even the first. They require no assembly or cutting, as the legs of the ladder are adjustable to suit the given height range. It comes with an



insulated door, a door seal to minimise drafts and dust, injection moulded non-slip EVA feet, and can be easily fitted with extra handrails to suit the client.

The high demand for this product proves how price affordable the Australian-made Ultimate Series ladder is when compared with similarly rated products. The design and materials have also proven to be successful in areas where white ants and termites are an issue.

Designed and engineered in Australia using CAD/CAM technology, Kimberley's total range can be customised to size, with Kimberley exercising full control over the manufacturing process through to the finished product.

Kimberley Products Pty Ltd began in 1955 as a toolmaking and plastic injection moulding company, but now concentrates solely on servicing the commercial and residential building and kitchen hardware markets. They supply major construction companies and distribute through national hardware retailers, backing up their products with technical assistance for all projects, large or small.



3

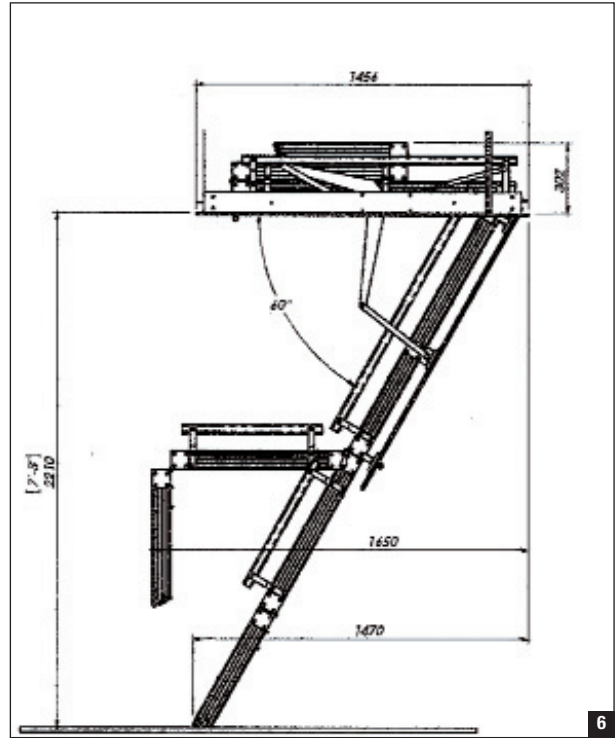

6

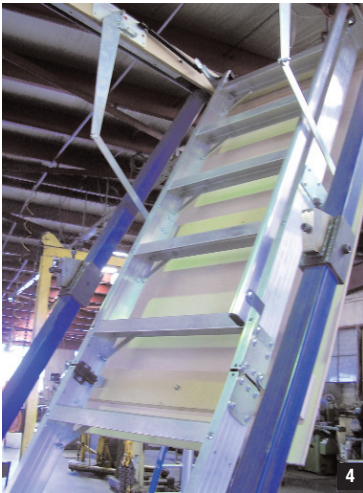

4



7

3. Concealed fixing method – without using architraves.
4. Factory testing and engineering during production stages.
5. Folddown stage of the Access ladder, illustrating the projection depth required.
6. Using CAD design technology, Kimberley can design and alter pitch, angle and length to suit the client's application.
7. Kimberley Products showroom – featuring various Access Ladders available for customers to view and trial.

PRODUCTS

Standard and Ultimate Series access ladders

AVAILABLE FROM

Kimberley Products and through National distributors

APPLICATIONS

Residential and commercial

FOR MORE INFORMATION

Kimberley Products

t: 03 9555 6744

e: kimprod@kimprod.com.au

w: www.kimprod.com.au



5